

SPECIFICATIONS

PHILCO AUTOMATIC RECORD CHANGER Part No. 35 - 1180 automatically changes either twelve 10" or ten 12" records. The service information contained in this bulletin covers the operation, care, and adjustments that may be necessary if the mechanism ceases to function properly.

When ordering parts for this mechanism, refer to the part number of the entire mechanism in addition to the number and names of the parts shown in the figures of this bulletin.

PHILCO RECORD PLAYER NEEDLES

To obtain brilliant life-like tone quality, PHILCO needles are recommended. These needles are especially designed to give high fidelity tone reproduction—less record wear and less surface noise. One needle plays 15 to 20 records. The use of inferior needles in the pick-up of this mechanism will greatly affect the tone reproduction performance.

CHANGER OPERATION

Setting for Record Size

This changer plays up to twelve 10-inch records or ten 12-inch records at one loading.

On each post you will see two plates. The lower one, on which the records rest, is the shelf plate. The upper one is the selector blade which selects the next record to be played from the bottom of the stack.

To set for record size. (1) Clasp one of the posts just underneath the shelf plate, with thumb and finger of left hand. With right hand, lift knob and turn selector plate until the figure 10 or 12 (whichever size you want to play) is opposite the pointer. Do the same with the other post. Both selector plates must be in 10 or 12 position. (2) Push button marked 10 or 12, as required (see Figure 1).

Loading

See that both shelf plates are turned toward center of turntable. As shelf plates near correct position you will feel the shelf plates drop into their indexing slots. Make sure both posts have dropped into their slots, if one is not in the slot, records may be damaged. Place the stack of records over center pin so they will rest on the two shelf plates.

Starting the Mechanism

To start motor and turntable (1) turn the switch to "ON" position. (2) Then push button "R". This will release the first record and start the record-changing mechanism.

Rejecting a Record

To reject a record press the "R" button. This can be done any time after the needle has come into contact with that record.

Turning Off

Turn changer switch to "OFF" position. Lift pickup arm, place it on the pickup rest. (If you happen to turn off the changer switch while the mechanism is going through a "change cycle", you will notice that it does not stop until the cycle has been completed, and pickup is again in playing position, ready to be lifted over onto the pickup rest.)

To avoid warping of records, never leave records resting on the shelf plates.

Removing Played Records

To remove records make sure motor switch is off, then take hold of both posts, just below the shelf plates, and turn

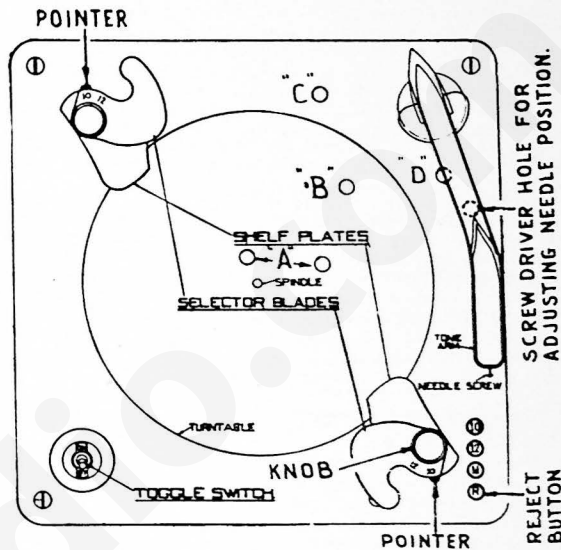

FIG. 1 SHOWS SELECTOR BLADES IN POSITION FOR 10-INCH RECORDS.

them out of the way. Lift the played records from the turntable. Taking hold of posts as before (below shelf plate) move plates until post again falls into indexed position as outlined under loading. The changer may then be loaded with a new stack of records.

Manual Operation

To play records one at a time as in an ordinary phonograph: (1) Remove any records remaining on the turntable, leave plates turned outward as for removing played records. Do not turn them back toward center of turntable. (2) Press button marked "M". Then place a record on the turntable, switch on motor and lift pickup into position.

LUBRICATION

The record changer will not need lubrication more than once a year and should be lubricated with a good light machine oil such as S.A.E. 10. There are 6 locations that will need oiling. These are shown in Figure 1. These lubricating holes can be reached from the top of the mechanism and are as follows:

1. The motor gear housing contains 3 lubricating wicks. These wicks are shown at "A" in Figure 1. Two of these wicks are reached through the hole directly in back of the turntable spindle and the other wick to the right of the turntable spindle.
2. A small quantity of oil should be dropped through hole marked "B" in Figure 1. Lubricating this point distributes oil to the various moving surfaces of the mechanism.
3. A felt wick directly below the hole marked "C" in Figure 1 should also be oiled.
4. Another felt wick marked "D" in Figure 1 should also be well oiled.

After long periods of use the oil becomes gummed in the above mentioned wicks. The wicks should be removed and cleaned with kerosene or carbon tetrachloride.

AUTOMATIC RECORD CHANGER--Part No. 35-1180

SQUEAKS OR OTHER NOISES DURING PLAYING OF RECORDS

If squeaks or various noises are heard from the mechanism during the playing of records or changing of records, the following items should be checked:

1. In the majority of the cases, these squeaks will be usually found to come from the friction between the stacked records and the turntable spindle. To check for this trouble, operate the mechanism with and without a load of records. To eliminate this condition, apply a very thin coat of light motor grease or vaseline to the turntable spindle.

2. Check the 5 wicks given under the paragraph on "Lubrication." Each wick should be thoroughly saturated with oil. All 3 motor wicks should be removed from the retaining holes with tweezers and examined to see if the oil has become gummy. In this case, the wicks should be thoroughly cleaned and relubricated with oil and replaced in their sockets.

3. Check all set screws to see that they are in place and tight.

4. Check motor windings. If coils have been jarred loose they should be tightened in place. The shading coils which encircle a portion of each laminated pole, the purpose of which is to make the motor self-starting, should be rigidly held in place by the retaining tape.

TURNTABLE SPEED VARIES

The turntable speed should be 78 R.P.M. + or - 2 R.P.M. when a record is being played, and the mechanism will operate satisfactorily. If the speed is below or above these limits, it indicates either trouble in the motor windings or bearings of the motor. Sometimes a few drops of oil on the bearings will increase the speed to normal. If upon investigation the normal speed cannot be obtained, replace the motor.

ADJUSTING LANDING POSITION OF NEEDLE ON RECORD

Adjustment of the landing position of the needle on records is controlled by the adjusting screw located in the hole shown in Figure 1. This adjustment is made with a screw driver from the top of the mechanism and does not require the removal of the changer from the cabinet. If the needle comes down too far from the edge of the record, playing of records will not start at their beginning. In this case, turn the needle positioning adjustment screw very slightly counter-clockwise. If the needle comes down too close to the edge of the record, the pickup may slip off the record. To adjust this condition turn the adjusting screw clock-wise. If adjustment screw is too far to rear and cannot be adjusted through hole in base plate, depress "Manual" push button, and push bracket—Forward.

NEEDLE FAILS TO MOVE INTO RECORD GROOVE AFTER LANDING ON RECORD

Generally when the needle will not pull into the groove after landing on the record, trouble may be found due to lead spring (97) being weak. Increasing the tension of this spring or replacing spring will generally eliminate the trouble.

If after adjusting the lead spring (97) it is found that the needle jumps across the record, it may be necessary to adjust the angle of the pickup in relation to the turntable spindle. This procedure is covered under paragraph "Mechanism Will Not Reject at the End of Records".

TONE ARM SLIDES INWARD ACROSS RECORD

This is caused by the guide arms stud (12) not releasing from the grooves in the upper side of the large cam gear (11). This may be due to friction at the shoulder screw (26) or the coil spring lifting the arm may be weak.

If the coil spring appears to be weak, it may be strengthened by shortening. If there is binding at the bearing, a little oil will help; also, a few movements by hand under considerable pressure will relieve the binding. If the binding is caused by the are being twisted out of line, the trouble can be sured by straightening up the parts.

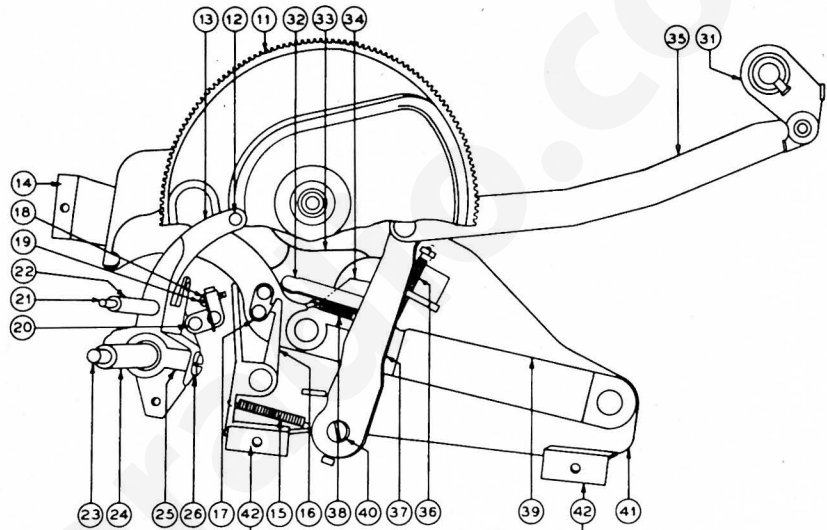

FIG. 2. CUTAWAY VIEW SHOWING PARTS UNDER SUB-PLATE ASSEMBLY (83) FIG. 3

Numbers on Figs. 2 and 3	PART DESCRIPTION	Numbers on Figs. 2 and 3	PART DESCRIPTION	Numbers on Figs. 2 and 3	PART DESCRIPTION
11	Cam Gear	38	Spring	77	Manual Rod
12	Stud	39	Cam Lever	78	Reject Rod
13	Guide Arm	40	Shoulder Screw	79	Extension Rod
14	Bracket	41	Sub-Plate	80	Truss Bar
15	Trigger Spring	42	Bracket	81	Adjusting Cam
16	Trigger	51	Grommet Sleeve	82	Cam Gear
17	Trigger Catch	52	Shim	83	Sub-Plate Assem.
18	Trip Adj. Screw	53	Main Plate	84	Spring
19	Lock Spring	54	Changer Switch	85	Cycling Switch
20	Release Lever	55	Motor	86	Bracket
21	Pickup Plunger	56	Connecting Plug	87	Spring
22	Pickup Sleeve	57	Changer Connect. Rod	88	Link
23	Swivel Shaft	58	Cam Connecting Rod	89	Release Lever
24	Swivel Tube	59	Spreader-Hub Assem.	90	Upper Spreader
25	Swivel Trunnion	60	Shaft	91	Lower Spreader
26	Shoulder Screw	61	Spring Roller	92	Rod
31	Spreader-Hub Assem.	62	Spreader Spring	93	Lever-Hub Assem.
32	Bridge	71	Post Nut	94	Lever
33	Lifter Cam	72	Lever-Hub Assem.	95	Swivel Spring
34	Pawl	73	Flat Spring	96	Lever Spring
35	Cam Connecting Rod	74	Shaft	97	Lead Spring
36	Spring	75	Key Unit		
37	Lift	76	Key Bracket		

ADJUSTING THE RISING HEIGHT OF PICK-UP ARM

The pick-up arm should rise high enough during the change cycle so that the top of the tone arm clears the record resting on the support arms by $\frac{1}{8}$ ". When the maximum load of records are on the turntable, the needle should clear the top record, if not adjust as follows:

Loosen the lock nut in pick-up sleeve (22). Turn the sleeve in the direction necessary to lengthen or shorten the pick-up plunger (21). After correct adjustment is found, tighten lock nut.

ADJUSTING DISTANCE FROM TURNTABLE SPINDLE AT WHICH REJECT WILL OPERATE AND CYCLE WILL BEGIN

The mechanism is designed to reject records of all types whether they are provided with special grooves or not. The mechanism is adjusted to operate 1 7/8" from the center of the record spindle; this distance has been found to be the most satisfactory point for all modern records so that they will be rejected after they have been played through. To adjust the reject mechanism for this distance or any distance that may be desired, a trip adjusting screw (18) is provided. By turning this screw toward the trip trigger (16), the mechanism is caused to operate at a closer distance from the spindle. Turning the adjusting screw (18) away from the trip trigger, operates the reject closer to the turntable spindle.

It may be found on some records of very early manufacture that it will not be possible to obtain a satisfactory adjustment that will always operate the changer mechanism.

MECHANISM WILL NOT REJECT AT THE END OF RECORDS

There are several parts that will cause the mechanism to fail in the operation of rejecting of records. These items are listed as follows:

1. Examine swivel spring (95) for stretching. This spring is attached to the lugs at the end of the swivel spreaders (90) (91). The purpose of this spring is to keep the swivel spreaders (90) (91) closed, so that the trip trigger can be actuated. Increasing the tension of the spring (95) will prevent the swivel spreaders from opening allow the trip trigger to actuate properly.

If after increasing the tension of the spring (95) it is found that the needle jumps across the record, it may be necessary to adjust the horizontal level of the pickup. Sometimes the pickup leans towards the center of the record. To remedy this condition, the pickup mounting post should be examined for proper mounting position or the pickup arm may be twisted out of shape. In either of these cases the pickup arm should be replaced or adjusted to its original position. When the pickup arm is properly adjusted, it should lean slightly in an outward direction (toward the edge of the record).

2. After it is found that the trip trigger (16) is operating properly, trouble may be found due to the cam lever (39) binding against sub-Plate (41). In this case, look for some obstruction or foreign material on these two parts. Also see that the rivets are operating freely. If lever (39) engages cam lever pawl (34) so that lift (37) forces its rollers up into the groove on cam gear (82) and if the set screws are tight, the change cycle should go into motion as the cam gear (82) turns.

3. Sometimes friction between the trigger (16) and trigger catch (17) due to burrs or rough surfaces may also prevent the reject from operating. If the trigger unlatches but the cam lever (39) does not move, it indicates binding between sliding surfaces. This may be caused by above mentioned burrs or by the cam lever being slightly warped.

To eliminate this condition, locate the position where there is excessive friction. If it is found that the parts are out of shape due to being bent, new parts should be added or the old ones straightened. When it is found that trouble is due to a burr on the edge of the metal parts, burrs should be removed with a very fine file or scraper. After eliminating this trouble, a small amount of oil should be applied to the sliding surfaces.

REJECT BUTTON "R" WILL NOT OPERATE MECHANISM

If the "R" button does not cause the mechanism to go through a change cycle check the following parts:

- a. Examine key control unit (75) for parts that have become out of shape or any obstruction that will prevent the "R" button from moving to its maximum length of travel.

- b. Inspect reject rod (78). If this rod does not trip the mechanism even when properly revolved by complete depressing of "R" button, the rod has probably been bent out of shape. Replace the rod or reshape it to its former position.

- c. If trigger (16) is properly actuated but without starting a change cycle see instructions as given under "Mechanism Will Not Reject at End of Records" paragraph 3.

PRESSING "M" BUTTON DOES NOT CHANGE MECHANISM FROM AUTOMATIC TO MANUAL POSITIONS

Observe action of "M" button. Button should travel far enough down when depressed to cause the manual rod (77) to actuate the key control unit. The key control unit (75) should also be checked for parts which have become out of shape or any foreign obstruction.

MOTOR STOPS IMMEDIATELY WHEN CHANGER SWITCH IS TURNED OFF DURING A CHANGE CYCLE

The normal action of the mechanism when the changer switch is turned off during a change cycle is to continue to operate until the needle is again on the record. The mechanism should then

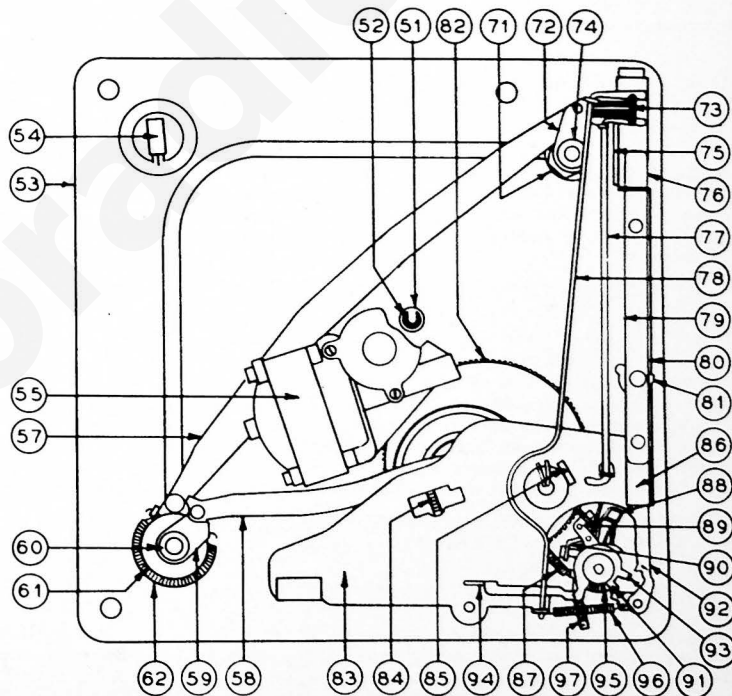

FIG. 3

stop. This action is caused by the cycling switch (85) short circuiting the manual changer switch during a change cycle. The switch should be changed when the above mentioned trouble develops.

TURNING CHANGER SWITCH OFF FAILS TO STOP MECHANISM

If after turning the changer switch off the mechanism continues to operate it indicates trouble in the cycling switch (85). Replace the switch when this trouble develops.

AUTOMATIC RECORD CHANGER---Part No. 35-1180

MECHANISM DOES NOT REPEAT THE LAST RECORD

If the mechanism does not repeat the last record, any one of the parts listed under "Mechanism Will Not Repeat at End of Records" may be causing the trouble.

RECORDS FALL UNEVENLY ON THE TURNTABLE

Records falling unevenly on the turntable is generally due to the turntable spindle not being correctly centered between the record loading posts. To correct this trouble, see "Replacing Motor."

LAST RECORD DROPS ON ONE SIDE

This trouble is due in most cases to the loading posts being bent out of perpendicular to the main plate. To check for this trouble, test the posts with a steel square as directed under "Replacing Motor". Replace or adjust post so that it will be perpendicular to the main plate.

CHANGER CONTINUES CYCLING

If the mechanism continues to change records constantly, it indicates trouble in the lift (37). Failure of this lift to disengage with the cam gear (11), Fig. 2, will cause the trouble. Check the various rivets at which motion occurs to find a point where friction or binding is interfering with freedom of motion. The cam lever (39), Fig. 2, should also be checked for too much friction. Oil this part if necessary.

SELECTOR BLADE FAILS TO SEPARATE BOTTOM RECORD FROM STACK

This is due either to a badly warped record or to its being of a thickness considerably different from records now in standard use. The selector blade and shelf blades are designed to accommodate a maximum variation in thickness and flatness of records now in standard use. There are certain records, however, that may be found which vary in thickness so much as to be impracticable for use in the automatic changers.

SELECTOR BLADES JAM INTO EDGE OF RECORD

This is generally caused by too small a spacing between the selector plate and the spacing between the selector plate and the shelf plate. This space should never be less than .050 inch when selector plate is in 10" position. Another cause of jamming is too sharp an edge on the selector plate.

To eliminate this trouble, check spacing of plates. Bend the selector plate slightly, if necessary. Smooth up the edge of the selector plate by means of a piece of fine emery cloth.

MECHANISM SLOW IN STARTING OR STALLS DURING A CHANGE OF CYCLE

Trouble is probably due to:

- Motor mechanism is not thoroughly lubricated. See heading "Lubrication".
- Check for loose set screws.
- Line voltage may be abnormally low or motor windings damaged. If the windings of the motor are damaged, replace motor. To remove motor, see heading "Replacing Motor".

REPLACING MOTOR

Replacing the motor necessitates extreme care in aligning and correctly mounting the new motor. The procedure listed below should be followed closely. When replacing a new motor or ordering a new one from your distributor, specify the power supply from which the motor is to be operated. The motor electrical wiring is shown in Fig. 4.

When mounting replacement motor, it is most important to see that record pin is centered between the two posts of the changer, that it stands perpendicular to main plate (53), and that it has not become bent so as to wobble. Even though the posts are stout and not easy to bend, it is well to check them also, with a 12" combination square laid clear across the concave upper surface of main plate. When the new motor has been attached, with three screws through grommet sleeves (51) (spacers) into its frame, and record pin is seen to revolve without appreciable wobble, the correct position of the record pin between the record-mounting posts can be accurately checked as follows: Place a single 12" record on the shelf plates, press "R" button, and turn turntable forward by hand. Immediately after the shelf plates open and allows the record to fall, turn turntable slightly backward, and with other hand support the record between the shelf plates; it can then be readily seen whether record pin is off center. If the record pin is found to be off center, remove the record and turntable, and loosen slightly the motor mounting screw or screws nearest the shelf plate to which record appeared closest. This should improve evenness of operation. However, unless the unevenness was very slight, it will be necessary for a permanent repair to insert a shim or two on one or more of the three screws (or change shims from one screw to another). The shims used are shaped like an ordinary washer, cut out at one side (see cut-away view at 52 on photo, showing a shim in place upon one of the grommet sleeves). Shims can readily be cut out with shears and punch from thin metal or cardboard—or an assortment of shims of different thicknesses can be had from your distributor. (Order "Assortment of Part No. 45-2785"). They should be inserted, around proper screws (when screws have been sufficiently loosened) between motor frame and the metal grommet sleeve. Do not insert shims next to rubber grommet.

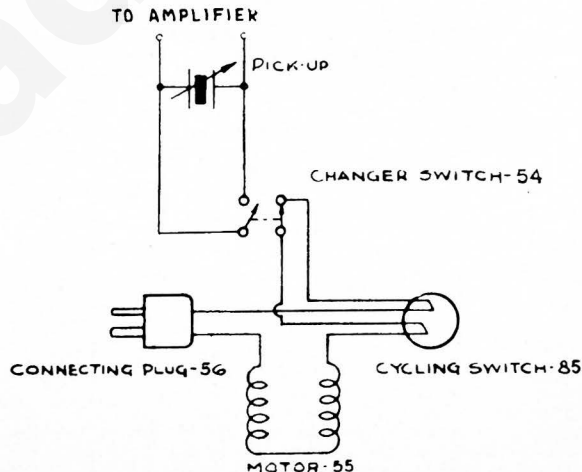

FIG. 4. MOTOR ELECTRICAL CONNECTIONS
DISASSEMBLING THE CHANGER

Before attempting to remove sub-plate assembly (83) detach key control unit (75) from main plate. To do this, start with control unit truss bar (80). Then take out the screw which holds left end of adjusting rod lever (94). Next remove adjusting rod (92) and adjusting rod extension (79). Take out the screw holding spring (73); then the screws holding key control unit (75) to main plate. Rods (77) and (78) can then, with due care, be extracted without bending. Free the cam connecting rod (58) by loosening setscrew holding spreader and hub assembly (59). Sub-plate assembly can then be detached without bending parts. In reassembling, reverse the procedure.